

CITY OF LOCKPORT
Roofing Application
 (Residential)

(Print Clearly)
 Applicant Name: _____ Phone #: _____

Address of work: _____

Owner Name: _____

Contractor: _____ Registration #: _____

***Please remember to attach a copy of a City of Lockport Certificate of Registration.**

Construction Value:\$ _____ Historic District (Yes/No)

Tear off: (Yes / No) Overlay: (Yes / No)

Shingle Type: _____

Felt paper: _____

Are you replacing sheathing: (Yes / No)

Type of sheathing: _____ Thickness: _____

Ice and water shield, felt, and gutter flashing are required and must be inspected before covering or shingles will be required to be removed for inspection.

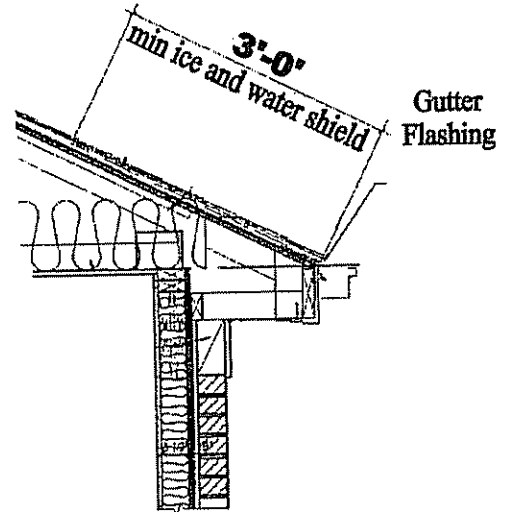

If two or more layers exist then you must tear off old shingles.

I hereby certify that I have read, understand and agree to conform to all governing information and regulations set forth by the City Council of Lockport.

Signature: _____ Date: _____

_____ **For Office Use Only** _____

Permit #: _____ Issued By: _____

Date Approved: _____ Permit Fee: _____

Comments: _____