

Guidelines for installing a lawn sprinkler system (2007)

Submittal:

- * Plat of survey showing the location of the sprinkler heads
- * Copy of contractor's City of Lockport Certificate of Registration.
- * Completed permit application

RPZ testing:

- * The annual RPZ test shall be submitted to the City of Lockport Building Department each year, within 15 days of the test.
- * Failure to submit this test within 15 days will result in an administrative ticket being issued to the contractor (\$50 penalty fee)
- * The RPZ test shall be completed at the time of installation of the sprinkler system.
- * RPZ tests must be completed annually by contractor registered with the City of Lockport.

Sprinkler Meter:

City Ordinance 51.078: Sprinkler Meter User

- A. A user of the City of Lockport sewer and water system may purchase a separate sprinkler meter for underground sprinkler systems only. The City of Lockport reserves the right to inspect said sprinkler meter to make sure it is being used solely for the above-mentioned purpose.
- B. The sprinkler meter shall be billed on the basis of water charges of the City of Lockport but shall not be billed for sewer charges.
*The water used for lawn sprinkler systems is not being discharged to the sanitary sewer system of each residence; therefore homeowners will save money on the sewer charge for the sprinkler water used. The homeowner will still be billed on the basis of water usage with the lawn sprinkler.
- C. The user shall be responsible for the installation of said meter at the actual cost of said meter plus \$50, which represents the City's service cost, and inspection of the meter.

The following are requirements for sprinkler meter installations:

- There shall be installed, on the inlet side of the meter, a full-port shut-off valve. There shall also be installed on the outlet side of the meter, a valve of like design. The meter shall be set in places readily accessible for removal and for reading, and set in such a manner as to prevent freezing or submersion in water. All meter shall have a working clearance on top of not less than sixteen (16") inches and on all other sides of not less than ten (10") inches.

Section 97.06.18- Meter transmitter unit/remote read: All building serviced by the City shall be equipped with a MXU and remote supplied and installed by the City.

Section 97.06.19- MXU/Remote Wire: The wire (supplies by the City) for the MXU and remote read shall be run by the contractor/developer. The wire shall be run ½ inch EMT conduit. The conduit shall be recessed one (1) inch from the exterior wall at a location near the natural gas meter, no lower than 36" from the ground elevation and run continuously to within twelve (12) inches of the water meter.

Section 97.06.20 Water Meter Final Inspection:

1. The MXU/remote unit will be installed according to Section 97.06.19
2. A 24-hour notice is required for final inspection
3. The b-box will be rechecked at this time.
4. Certain accessories or equipment may require a backflow device.

(In addition to the above-mentioned requirements, the installation must meet the State of Illinois Plumbing Code.)

State Plumbing Code:

890.1140 A) Lawn Sprinklers. Any lawn sprinkler system connected to a portable water supply shall be equipped with a reduced pressure principal backflow preventer assembly (RPZ) may be located outside provided it conforms to section 890.1130 (G) (1).

890.1130 B) Approval of Devices and Maintenance. All devices for prevention of backflow or back siphonage shall comply with the standard listed in Appendix A, Table A, "Approved Standards for plumbing Appliance/Appurtenances/Devices". Each double check valve backflow preventer with intermediate atmospheric vent assembly (RPZ) shall be tested in-line and approved by a cross-connection control device inspector before being placed into service. Such backflow preventers (DVCs, double check backflow preventer with intermediate atmospheric vent assemblies, and RPZs) installed in a portable water supply system shall be tested and maintained at least annually by a cross-connection control device inspector, and records to verify testing and maintenance shall be available at the site of the installation of the device or at other approved locations.

Final Inspection:

A final inspection must be scheduled upon completion of the lawn sprinkler system. This inspection is to verify the plumbing was installed correctly. This inspection is **not** for the RPZ testing. Failure to schedule this inspection will result in additional fines.

Electrical Requirements:

All wiring per 2002 National Electric Code. A dedicated circuit is required; the size would be based on amperage of pump motor. (Motors up to 12 amps may be run on a 15 amp breaker.) Pumps may be hard wired, with a disconnect within sight of the pump or plug connection. If the cord is connected, the cord must be 6' or less and plugged into a single outlet **without extension cords.** (No duplex receptacles allowed)

Contractor Registration:

All contractors working within the City of Lockport are required to be registered. No permits will be issued if the contractor is not registered. A copy of a City of Lockport Certificate of Registration is required to be submitted with all applications.

**If you are doing the work as the homeowner, registration is not required.

Recommended installation of Lawn Sprinkler Meters

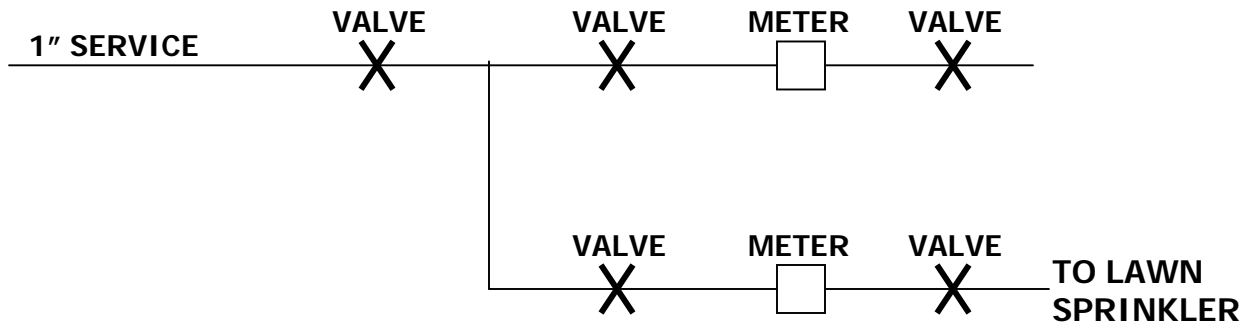

Warning:

The Water Department will not refund any money to the Homeowner for excess water charges if the lawn sprinkler meter is installed incorrectly.

CITY OF LOCKPORT

LAWN SPRINKLER APPLICATION

(Please print legibly)

Applicant Name: _____ Phone #: _____

Address of lawn sprinkler: _____

Owner Name: _____

Estimated Value: \$ _____

Contractor: _____

Contractor Registration #: _____

***Please remember to attach a copy of a City of Lockport Certificate of Registration**

1. Will there be a pump installed at this location? Yes _____ No _____

(If so, a low pressure cut off switch shall be installed on the suction side of the pump)
A shut-off valve shall be installed on suction and within 5' of the pump suction inlet, and pressure gauge shall be installed between shut-off valve and pump.

2. If so, is there an outlet within 5' of the pump location? Yes _____ No _____

Pump shall also require unions on inlet and outlet, and shall be secured to the floor.

If no pump and/or sprinkler meter, a shut off valve will be required. The required valve will need to be purchased from City of Lockport (1" full port IPS Nibco ball valve)

3. Would you like to purchase a second meter? Yes _____ No _____

(A sprinkler meter will also require (2) ball valves purchased from the City of Lockport. Install valves on inlet and outlet of sprinkler meter.)

I hereby certify that I have read, understand, and agree to conform to all governing information and regulations set forth by the City Council of Lockport.

Signature: _____ Date: _____

_____ **FOR OFFICE USE ONLY** _____

Permit #: _____

Issued By: _____ Date Issued: _____

Comments: _____